

# Electric Strut Served Window

COMMERCIAL SERIES - 125mm FRAME

## Vertical X-Section Details

SHOWN WITH HARDWOOD REVEALS

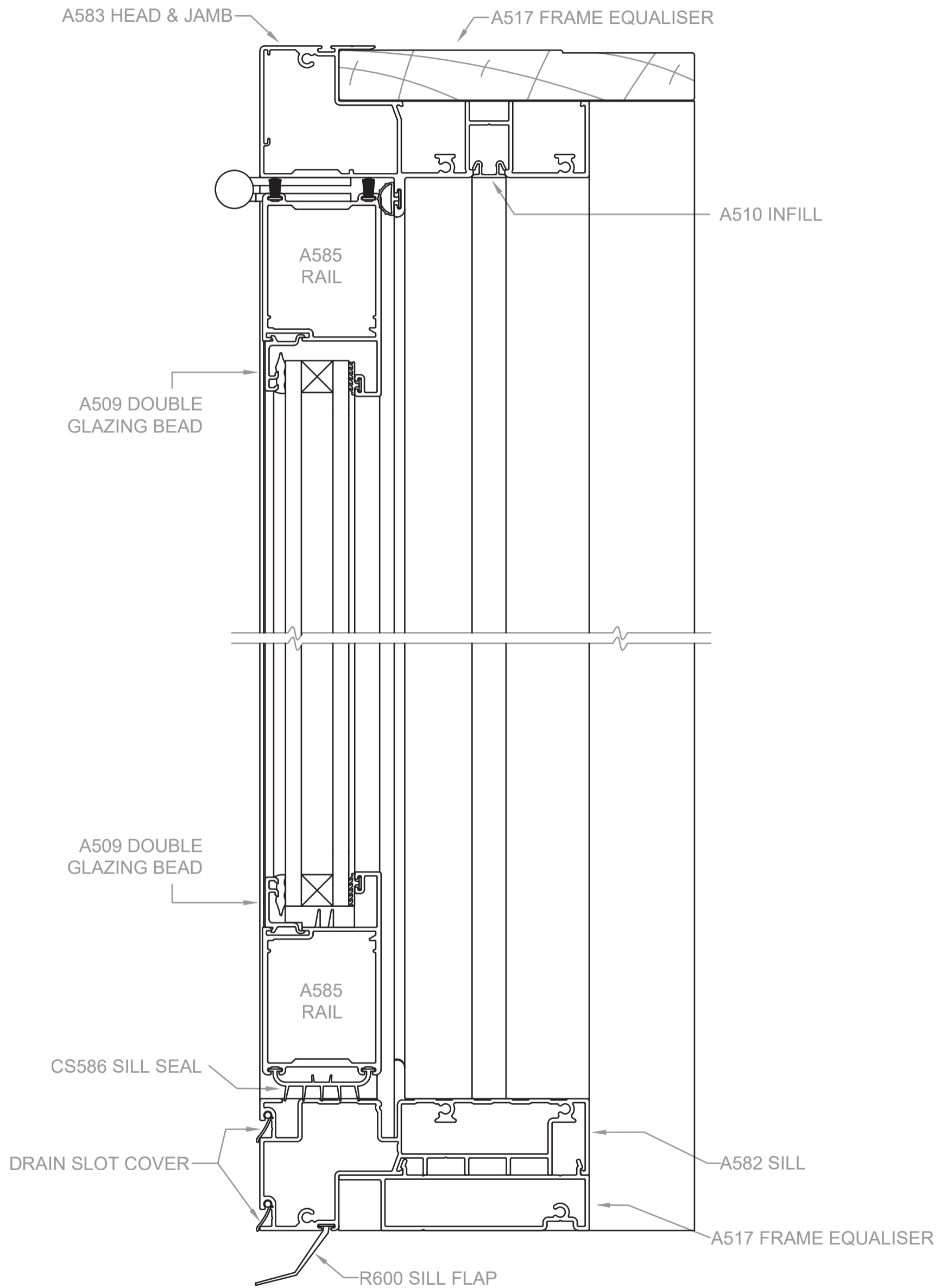

# Electric Strut Servery Window

COMMERCIAL SERIES - 125mm FRAME

## Horizontal X-Section Details

SHOWN WITH HARDWOOD REVEALS

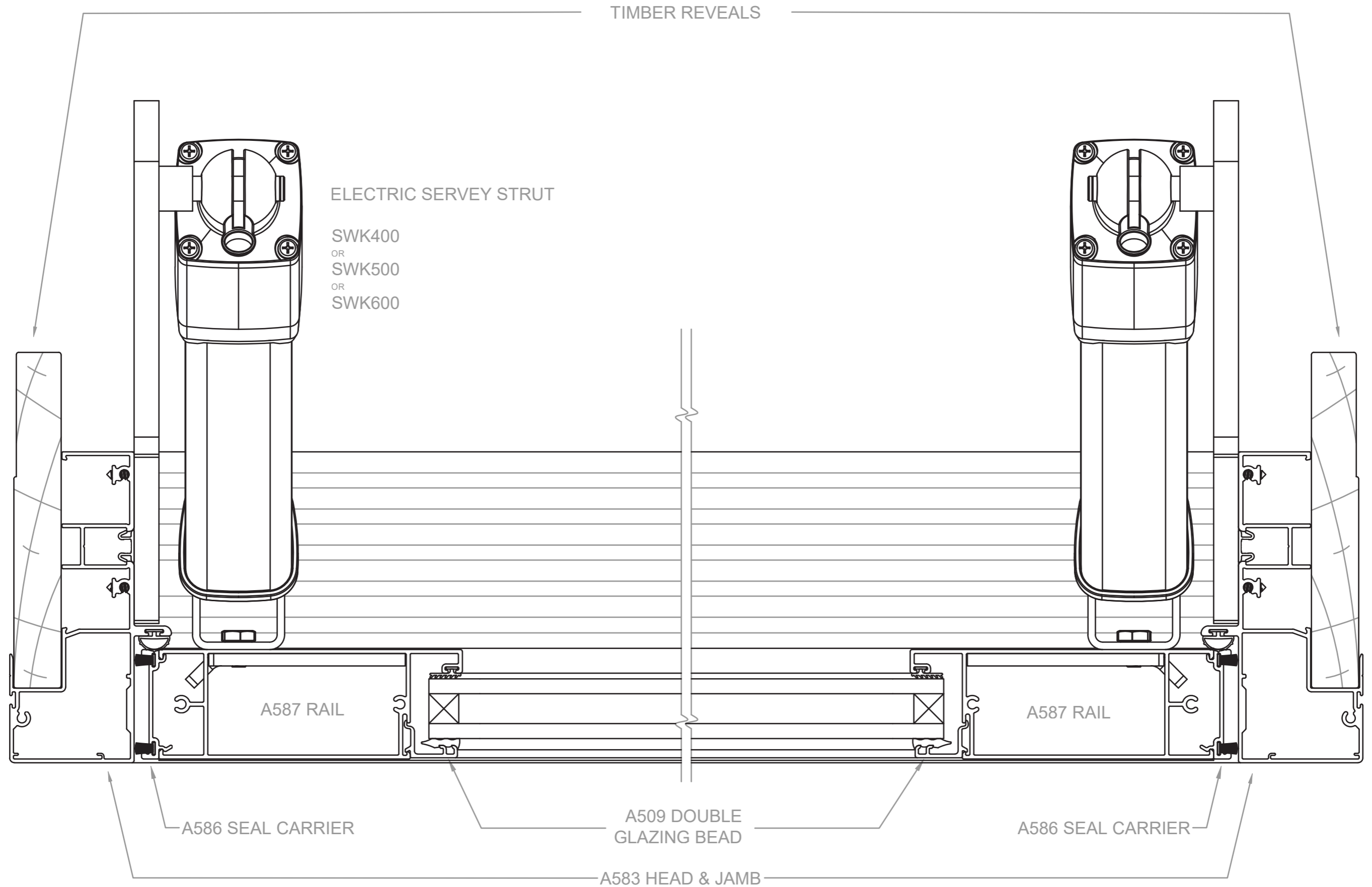

# Electric Strut Served Window

COMMERCIAL SERIES - 125mm FRAME

## Vertical X-Section Details

SHOWN WITH REVEAL EQUALISER

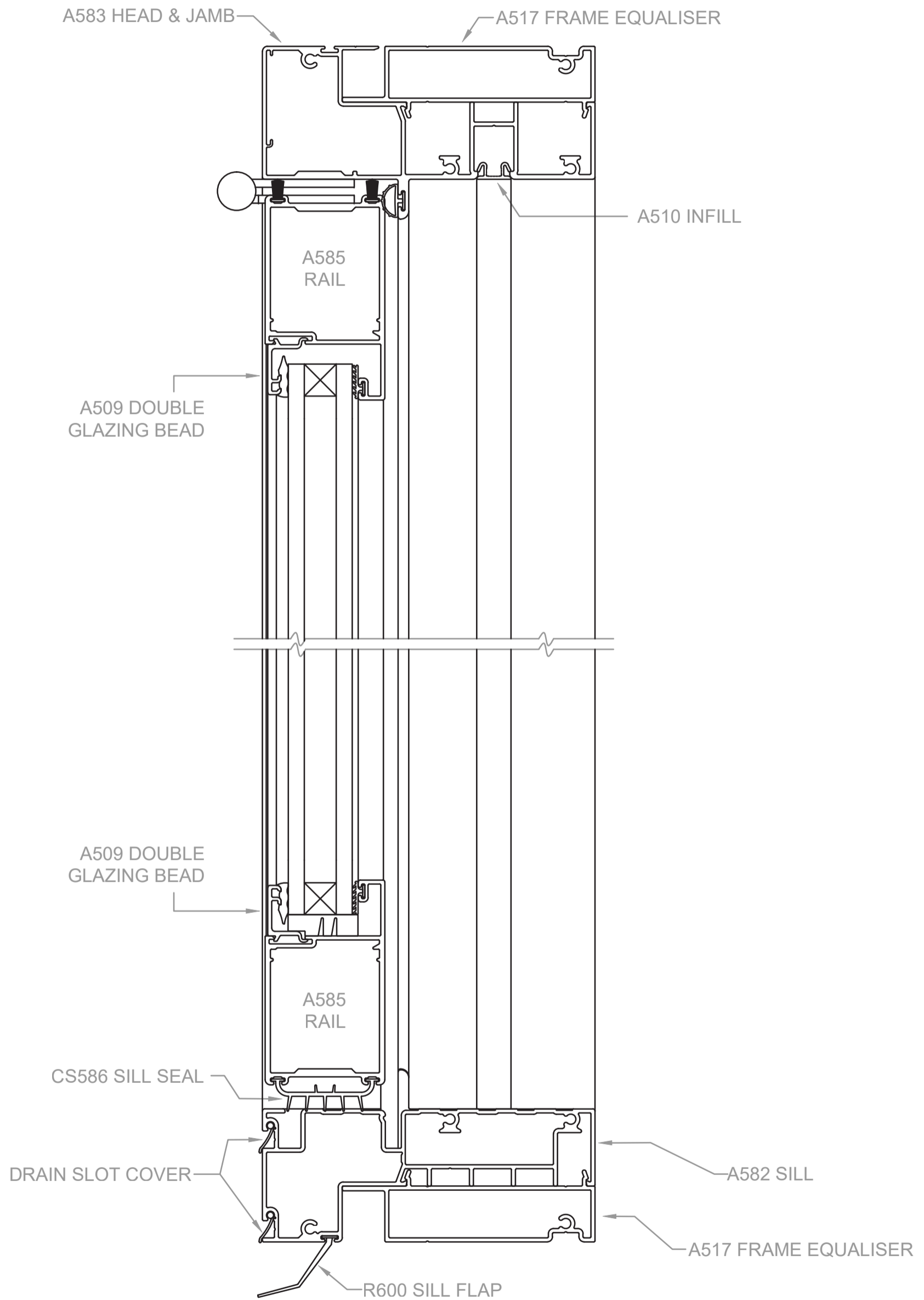

# Electric Strut Served Window

COMMERCIAL SERIES - 125mm FRAME

## Horizontal X-Section Details

SHOWN WITH REVEAL EQUALISER

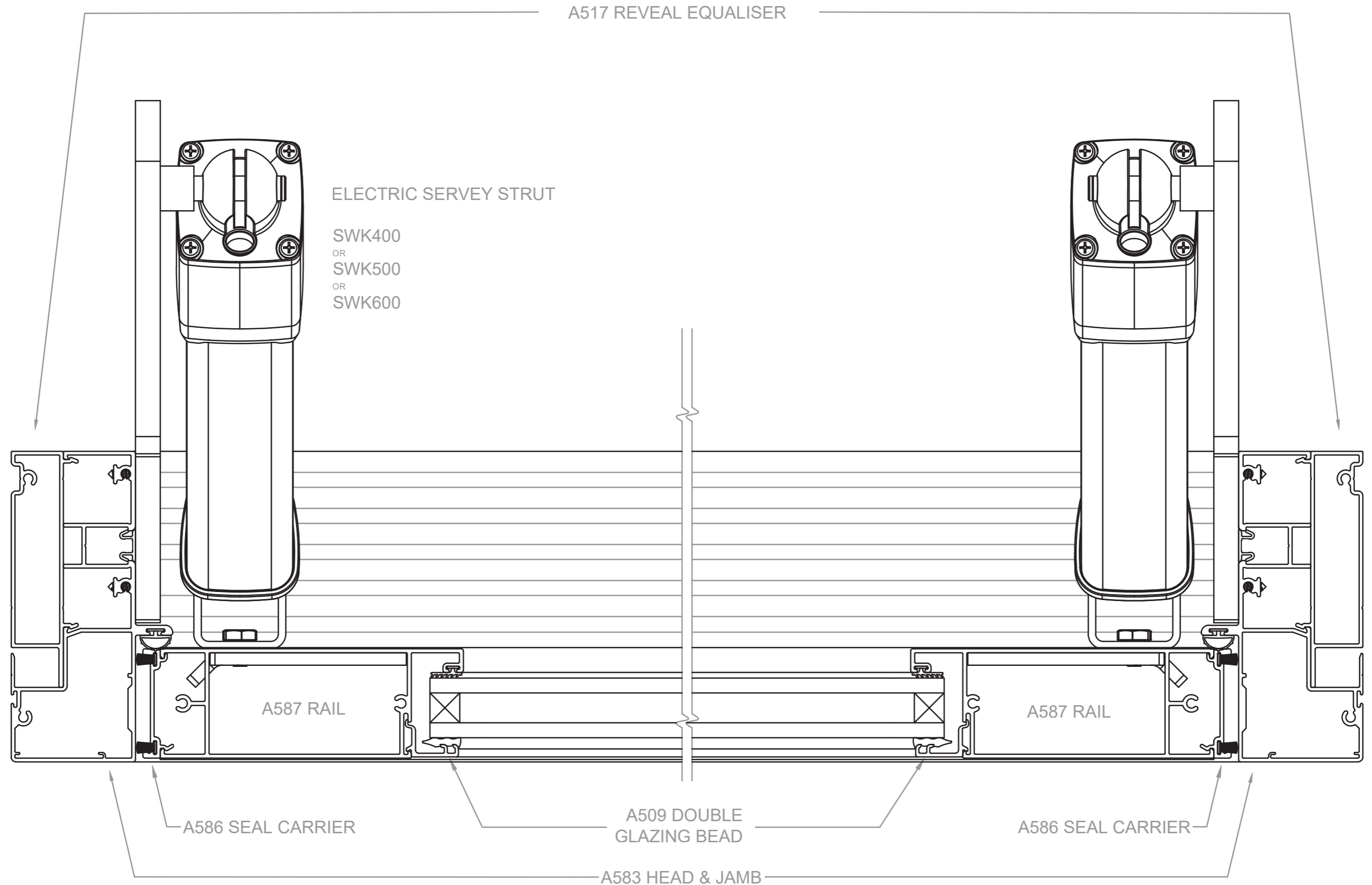

# Electric Strut Served Window

## Vertical X-Section Details

COMMERCIAL SERIES - 125mm FRAME

SHOWN WITH TIMBER REVEALS - 3 SIDED NO SILL

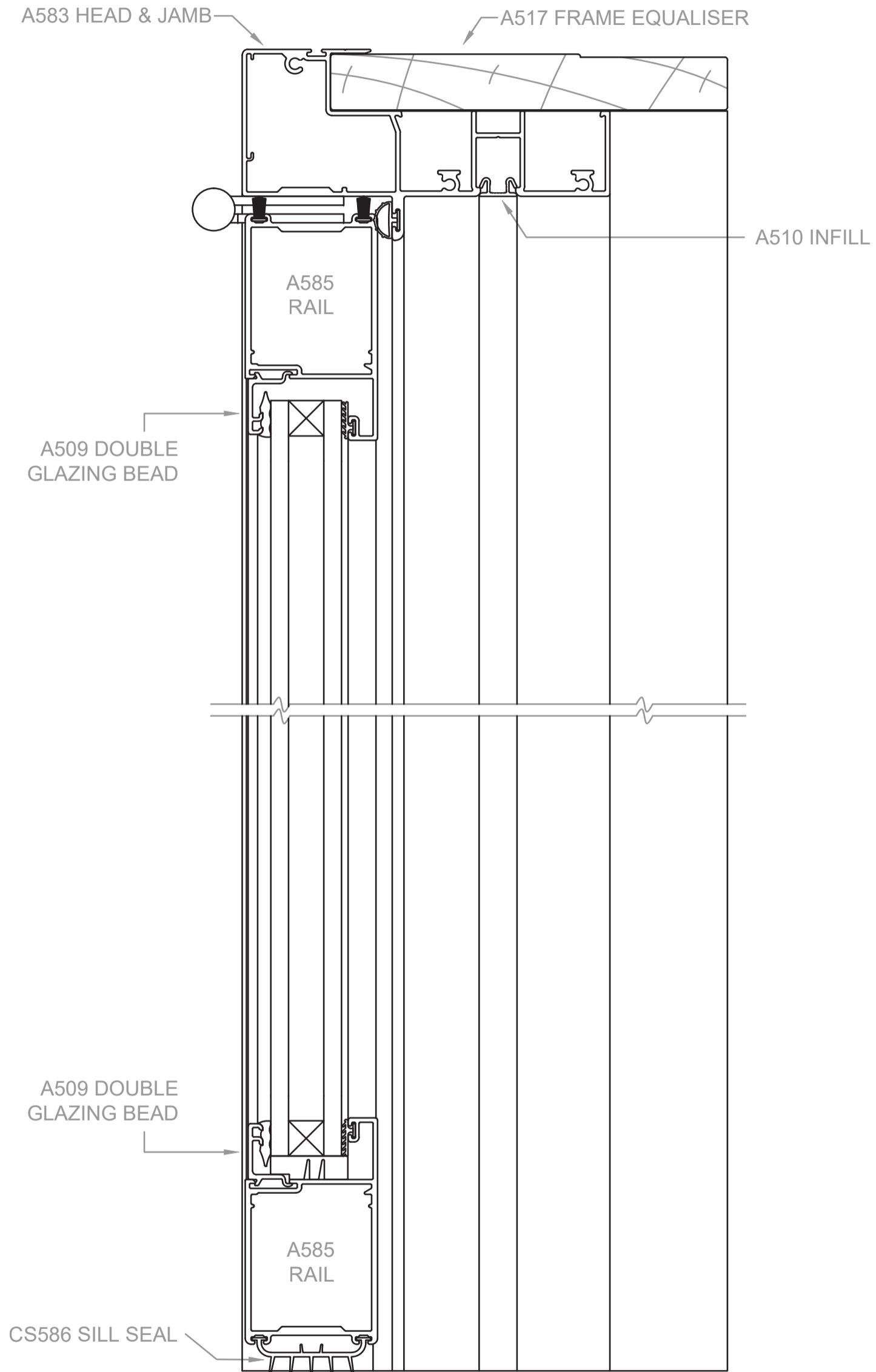

# Electric Strut Served Window

## Vertical X-Section Details

COMMERCIAL SERIES - 125mm FRAME

SHOWN WITH REVEAL EQUALISED - 3 SIDED NO SILL

